

# LOUSS

Lighting Emotion



## MYSTA ON TRACK



## MYSTA ON TRACK

## 48V-Stucchi

## 230V

<b>Range</b>	Adjustable low luminance spotlight on track for general and accent lighting			
<b>Description</b>	Low luminance Rotation 355° - Adjustable tilt 90° <b>En option</b> : Changement de LED, optique & accessoires sur site sans outil, grâce au système <b>Easy Swap</b> (voir page 4)			
<b>Finish</b>	White RAL 9003 matt finish Black RAL 9005 matt finish (other upon request)			
<b>Dimensions</b>	<b>48V-Stucchi</b>	<b>230V</b>		
	<b>Spotlight</b> Spotlight diameter : 46mm Spotlight length : 64mm Driver length : 98mm (On/Off, PWM) 166mm (DALI)  <b>Track - Stucchi Evo System</b> ST1 : 26.2 x 21mm (For other EVO-S tracks, please see Stucchi documentation)	<b>Spotlight</b> Spotlight diameter : 46mm Spotlight length : 64mm Driver length : 162mm (On/Off - 700mA) 228mm (On/Off - 1,050mA) 253mm (DALI - 700mA)		
<b>Net weight</b>	<b>48V-Stucchi</b>	<b>230V</b>		
	<b>Spotlight</b> 0.180 kg  <b>Track - Stucchi Evo System</b> ST1 : 0.70 kg/m (For other EVO-S tracks, please see Stucchi documentation)	<b>Spotlight</b> 0.250 kg (without track)		
<b>LED characteristics</b>	2700K - 3000K - 3500K - 4000K - 5000K (other upon request) MacAdam ellipse : 3 SDCM (standard version) - 2 SDCM (premium version) CRI90 (standard version) - CRI95, R9 > 80 (premium version)			
<b>Optical beams &amp; Performances</b>	<b>Beam</b>	<b>Candela</b>	<b>Power</b>	<b>Photometry</b>
	11°	10 900cd (3000K)	7W	ies 2591A
	16°	6 300 cd (3500K)	8W	ies 2645A
	20°	4 400 cd (3500K)	7W	ies 2510A
	23°	3 100 cd (3500K)	7W	ies 2511A
	34°	1 700 cd (3500K)	8W	ies 2617B
43°	1 050 cd (3500K)	7W	ies 2513A	

All the connections have to be made before powering up, otherwise the luminaires could be seriously damaged

Creation : 2025.04.08 / Last update : 2026.04.08

LOUSS

BEST SAS, Capital 200 000€  
 RCS Dijon B 408 483 485  
 TVA/VAT n° : FR94 408 483 485  
 APE 2612Z

Tel. : +33 380 48 65 68  
 contact@louss.fr  
 www.louss.fr  
 Best & LOUSS

Siège social / Head Office  
 PA Les Terres d'Or  
 Route de Saint Philibert  
 21220 Gevrey Chambertin - FRANCE



## MYSTA ON TRACK

## 48V-Stucchi

## 230V

<b>Performances</b>	300 to 800 lumen UGR < 15	
<b>Accessories</b>	Filters, honeycomb grid upon request	
<b>Power</b>	4W to 10W according to version	
<b>Power supply</b>	<b>48V-Stucchi</b>	<b>230V</b>
	Spot adaptor for 48V Stucchi EVO-S track Separate power supply 230V/48V ON/OFF, PWM or DALI driver	Driver suitable for Global Trac Pro XTS track or equivalent (Ercos, Trajectoire...) 700mA or 1,050mA max. ON/OFF driver or 700mA max. DALI driver
<b>Use limitations</b>	The product must be installed into a ventilated area Any use with an ambient temperature higher than the specified ambient temperature (Ta) would lead to a more rapid mortality of the product and the withdrawal of our guarantees The drivers, if not delivered by LOuss, must be approved before use	
<b>Warranty</b>	Life span: L80B10 at 50,000 hours (80% remaining flux) at 25°C ambient temperature. 3-year parts and labor warranty The warranty does not apply to products that have been opened, modified or repaired and does not cover the effects of a wrong connection, careless, abusive handling, overvoltage, lighting injury, as well as the normal wear of the product All products are electrically tested and received a functional burn-in	

All the connections have to be made before powering up, otherwise the luminaires could be seriously damaged

Creation : 2025.04.08 / Last update : 2026.04.08

LOuss

BEST SAS, Capital 200 000€  
RCS Dijon B 408 483 485  
TVA/VAT n° : FR94 408 483 485  
APE 2612Z

Tel. : +33 380 48 65 68  
contact@louss.fr  
www.louss.fr  
Best & LOuss

Siège social / Head Office  
PA Les Terres d'Or  
Route de Saint Philibert  
21220 Gevrey Chambertin - FRANCE



## MYSTA ON TRACK • 48V-Stucchi • 230V

### Easy swap system



All the connections have to be made before powering up,  
otherwise the luminaires could be seriously damaged

Creation : 2025.04.08 / Last update : 2026.04.08

LOUSS

BEST SAS, Capital 200 000€  
RCS Dijon B 408 483 485  
TVA/VAT n° : FR94 408 483 485  
APE 2612Z

Tel. : +33 380 48 65 68  
contact@louss.fr  
[www.louss.fr](http://www.louss.fr)  
Best & LOUSS

Siège social / Head Office  
PA Les Terres d'Or  
Route de Saint Philibert  
21220 Gevrey Chambertin - FRANCE



## MYSTA ON TRACK 48V-S

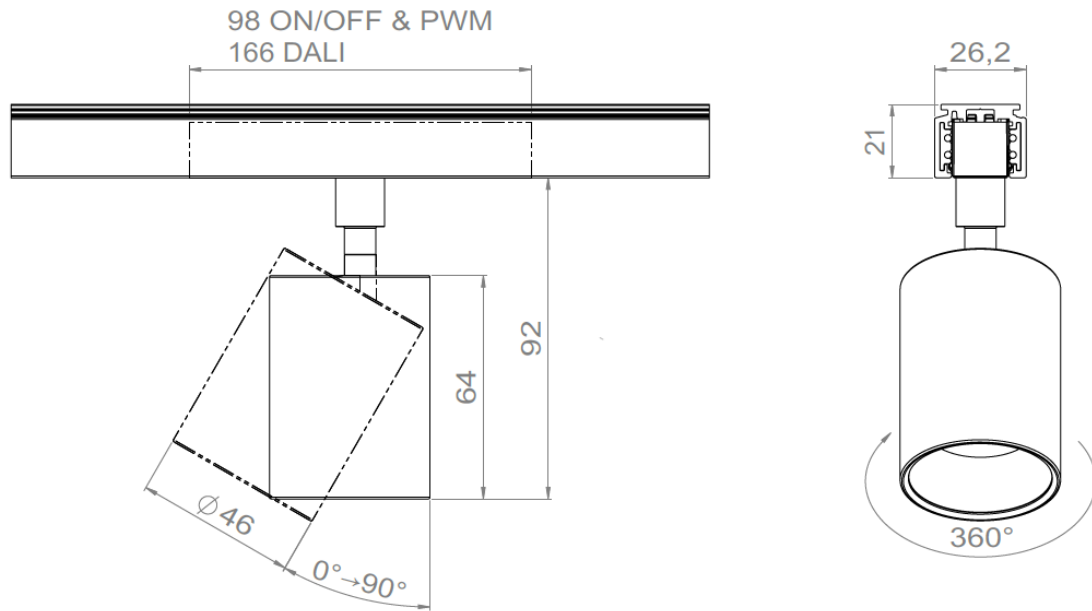

## MYSTA ON TRACK 230V

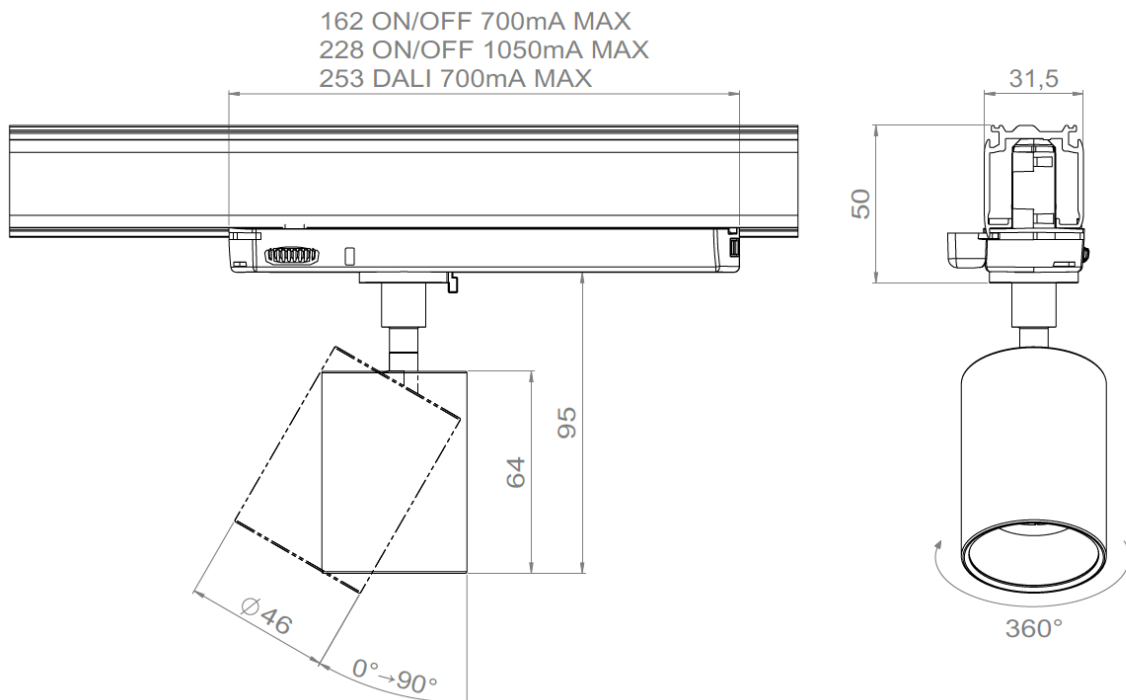

All the connections have to be made before powering up,  
otherwise the luminaires could be seriously damaged

Creation : 2025.04.08 / Last update : 2026.04.08

LOUSS

BEST SAS, Capital 200 000€  
RCS Dijon B 408 483 485  
TVA/VAT n° : FR94 408 483 485  
APE 2612Z

Tel. : +33 380 48 65 68  
contact@louss.fr  
[www.louss.fr](http://www.louss.fr)  
Best & LOUSS

Siège social / Head Office  
PA Les Terres d'Or  
Route de Saint Philibert  
21220 Gevrey Chambertin - FRANCE